

Gasmate®

GALAXY GEN2 CORNER MODULE





Model No. BQ3052



IMPORTANT: RETAIN THESE INSTRUCTIONS FOR FUTURE USE.

Gasmate® is a registered trademark of Sitro Group Australia Pty Ltd
www.gasmate.com.au Aber Living, N.Z. www.gasmate.co.nz

SCREW PACK LIST

Screw Packs	Image	Description	Quantity
Screw Pack - B1		M6 x 15 Bolt	16
		M6 Spring Washers	16
		M6 Flat Washers	16
Screw Pack - B2		M5 Step Bolt	8
		M5 x 10 Bolt	53

PARTS LIST

Parts No.	Description	Quantity
1	Bottom panel	1
2	Casters	4
3	Front fascia	1
4	Vertical supports	3
5	Connecting beams - middle & bottom	4
6	Top supporting beams - Front	2
7	Top supporting beams - Back	2
8	Top module	1
9	Back covers	2

CASTERS ASSEMBLY

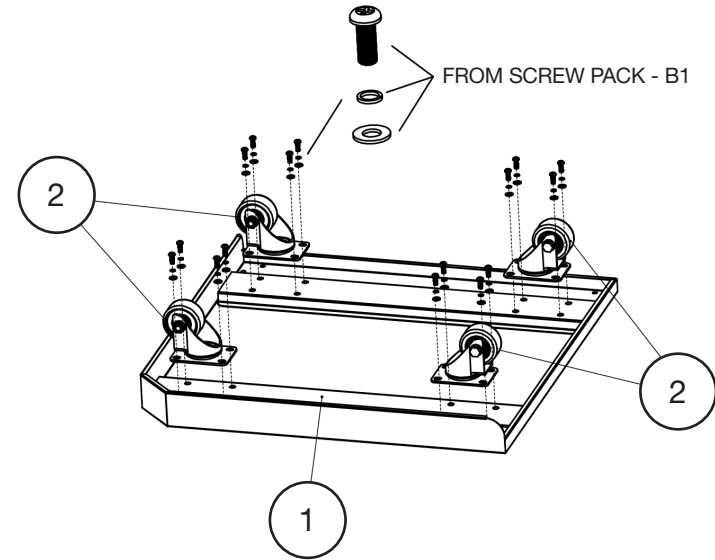

INSTALL FRONT FASCIA

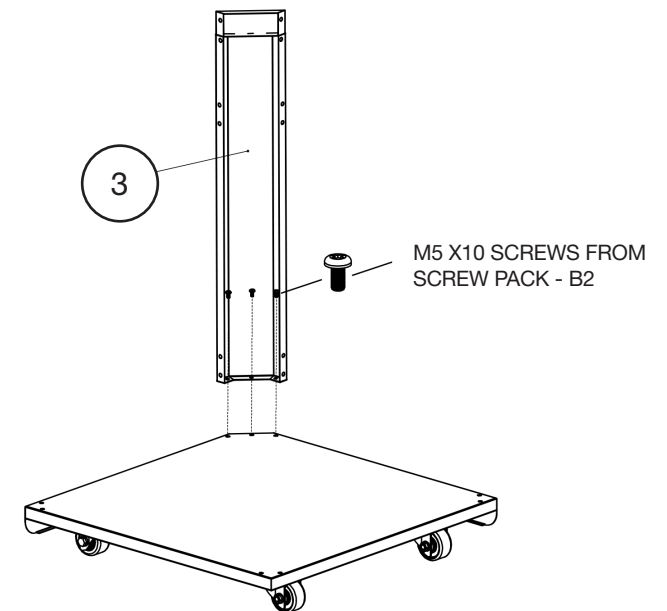

VERTICAL SUPPORT ASSEMBLY

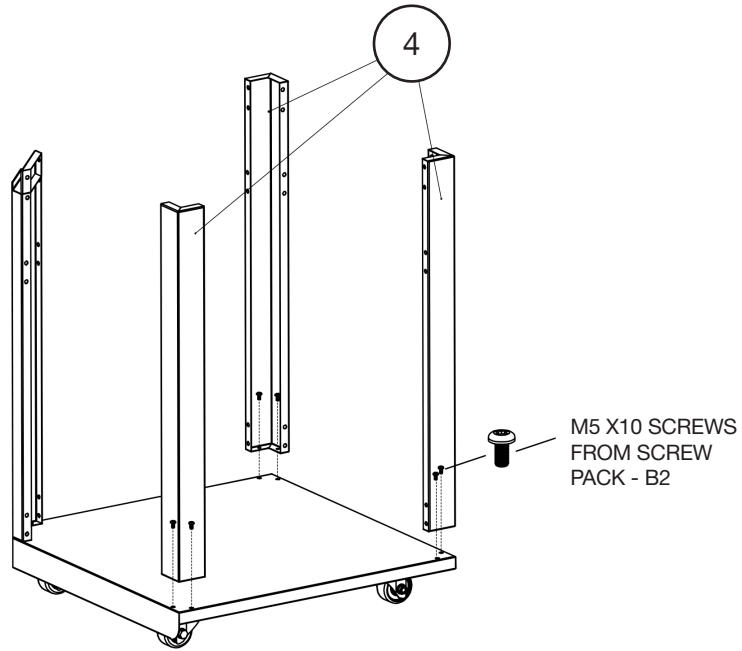

FRAMEWORK ASSEMBLY

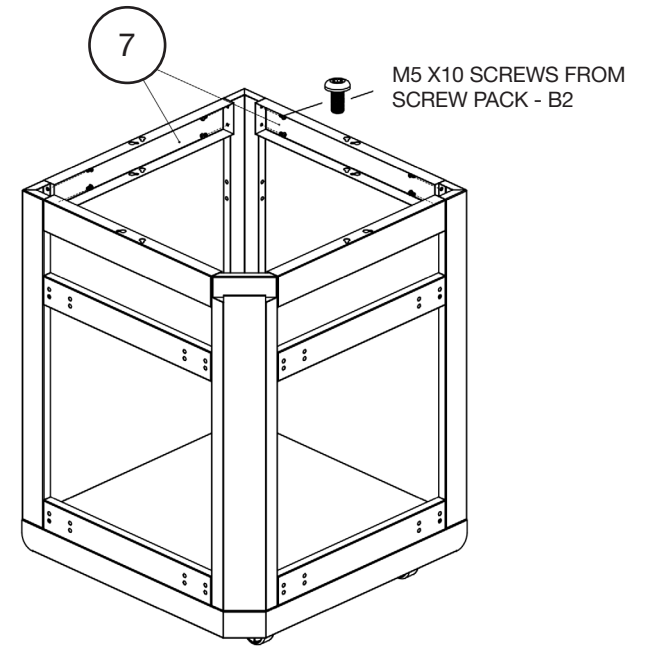

FRAMEWORK ASSEMBLY

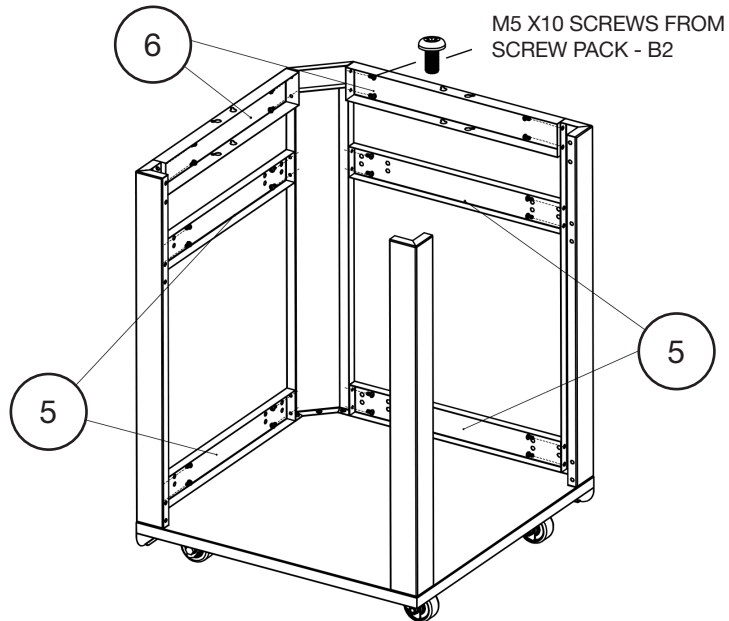

TOP MODULE ASSEMBLY - PREPARATION

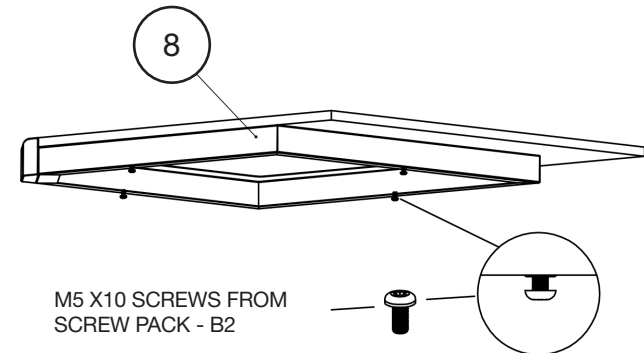

Partially install the M5x10 bolts into the Top Module assembly, leaving them loose for the following step.

TOP MODULE ASSEMBLY

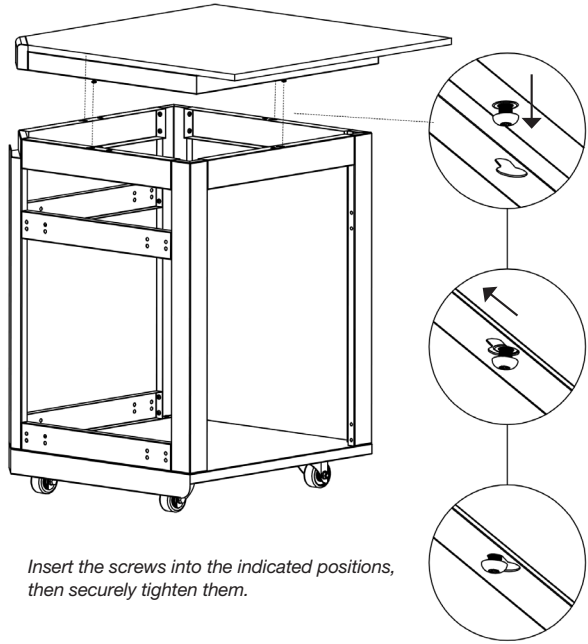

BACK PANELS ASSEMBLY

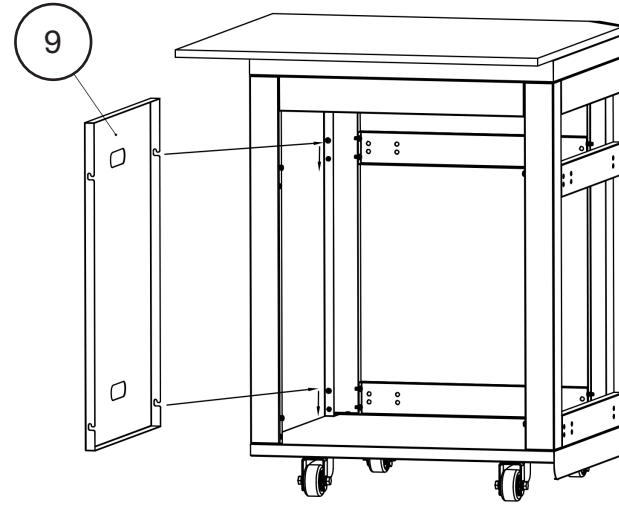

BACK PANEL MOUNTING BOLTS ASSEMBLY

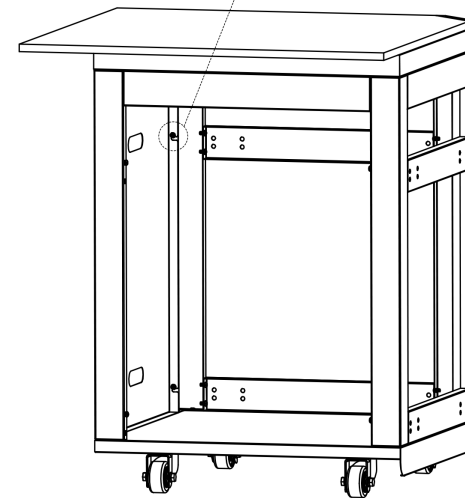
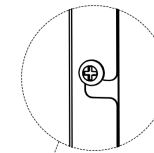
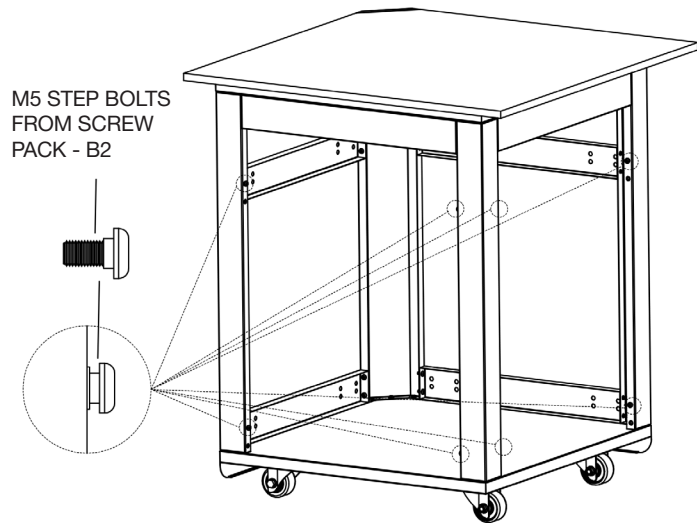

Please turn over to continue

CONNECTING THE CORNER MODULE TO OTHER MODULES

M5 X10 SCREWS FROM
SCREW PACK - B2



For any queries or assistance call



Customer Service
(Australia Only)

1300 174 876

Hours of operation:
Monday to Friday 8am - 5pm EST

Gasmate