



PORTABLE DIESEL HEATER

Model No. GM20-425

SERVICE MANUAL



Contents

| | | | |
|--|----|---|----|
| How to remove the outer metal cover of the heater unit | 2 | Main parts of heater unit | 11 |
| How to replace the glow plug | 3 | How to disassemble the combustion chamber | 12 |
| How to replace the temperature sensor | 5 | Removing dust and debris from the exterior surfaces | 19 |
| How to replace the PCB | 7 | Draining and cleaning the fuel tank | 19 |
| How to remove and clean the air filter | 9 | Flushing the fuel lines | 19 |
| How to change the fuel pump | 10 | | |

Important: Retain these instructions for future use.

HOW TO REMOVE THE OUTER METAL COVER OF THE HEATER UNIT

TOOLS REQUIRED:

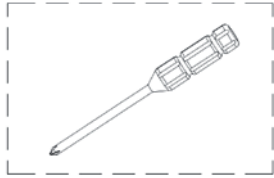

Phillips head screwdriver

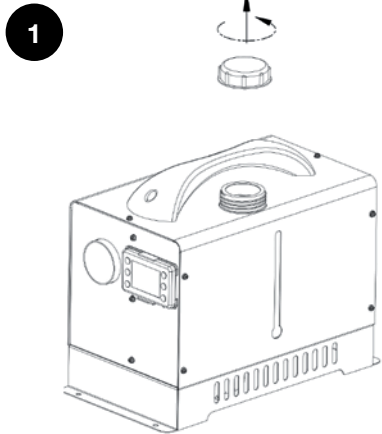

1. Unscrew the fuel tank cap and remove.
2. Using a phillips head screwdriver, unscrew and remove the 4 screws on each side of the case and 2 screws on the top (note the screws on the ends of the case can remain).
3. Carefully lift the outer case up and off.

NOTE: While working on the heater unit with the outer case off it is recommended to replace the fuel cap to prevent fuel spillage.

Reattachment of the cover is the reverse of this process.

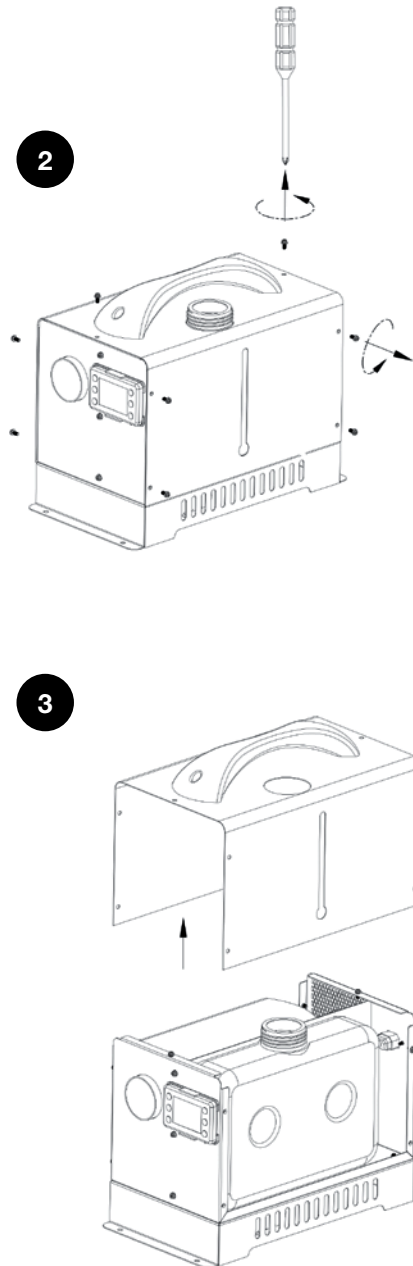

HOW TO REPLACE THE GLOW PLUG

PARTS & TOOLS REQUIRED:

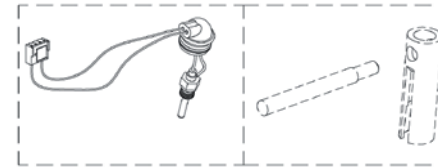

Glow Plug & Harness

Glow Plug removal tool

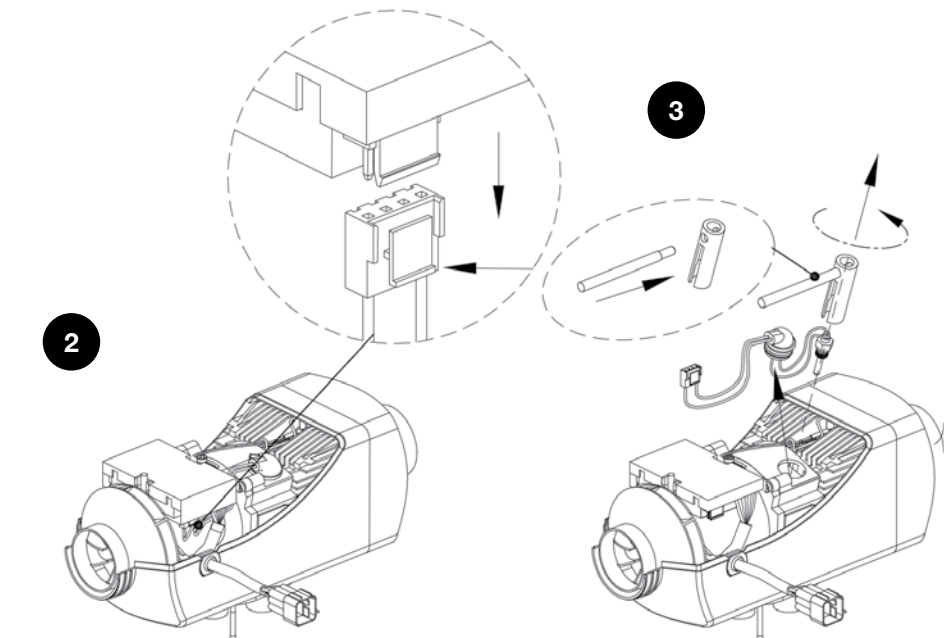
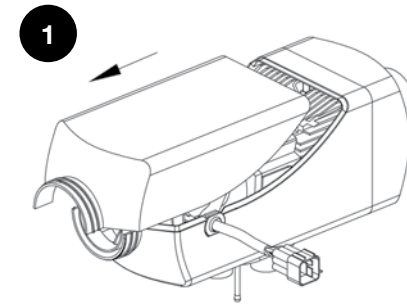

After removal of the outer metal cover of the heater, you can access the heater unit. Replacement of the glow plug can be done without removing the heater unit from the case, however you might find it easier to remove it if doing additional work.

1. Remove the upper cover of the heater unit .
2. Access the connector for the glow plug harness on the front right side of the PCB as shown and remove.
3. Remove the rubber plug over the glow plug and using the special removal tool, carefully unscrew the glow plug.

NOTE: Be careful when unscrewing the glow plug to not twist the wires or the attached harness and damaging them.

With the glow plug out, check the condition of the glow plug and also the condition of the mesh screen inside the combustion chamber (use a small torch to see better inside the opening). If there is a lot of carbon build-up on the glow plug or the screen it is recommended to disassemble and clean the combustion chamber.



Please continue on the following page

HOW TO REPLACE THE GLOW PLUG - Continued

4. Carefully insert the new Glow Plug into the opening and screw in.

NOTE: Be very careful to not cross-thread when screwing it in and to rotate the harness wires around with the glow plug so they do not get twisted and damaged.

5. Once tightened down fully, feed the harness wires back in position and plug into the PCB.

6. Reattach the top cover of the heater unit.

The outer metal cover can now be attached and the heater tested.

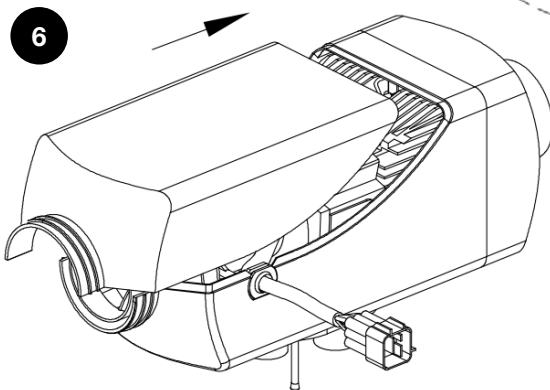
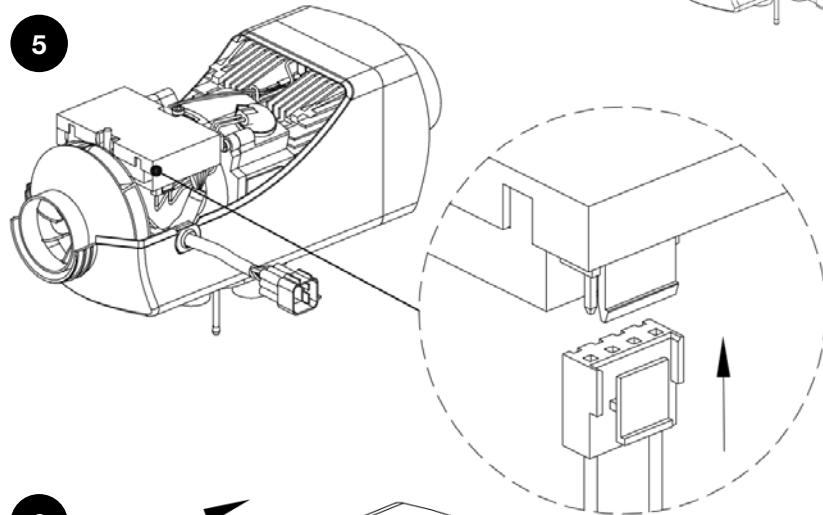
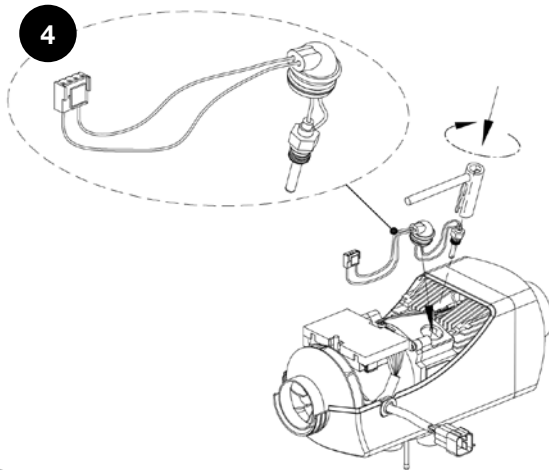

HOW TO REPLACE THE TEMPERATURE SENSOR

PARTS REQUIRED:



Temperature Sensor & Harness

After removal of the outer metal cover of the heater, you can access the heater unit. Replacement of the temperature sensor can be done without removing the heater unit from the main case, however you might find it easier to remove it if doing additional work.

1. Remove the upper cover of the heater unit .
2. Access the connector for the temperature sensor harness on the front left side of the PCB as shown and remove.
3. Remove the retaining clip for the temperature sensor and lift off the sensor.

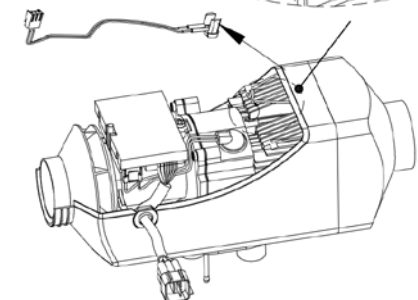
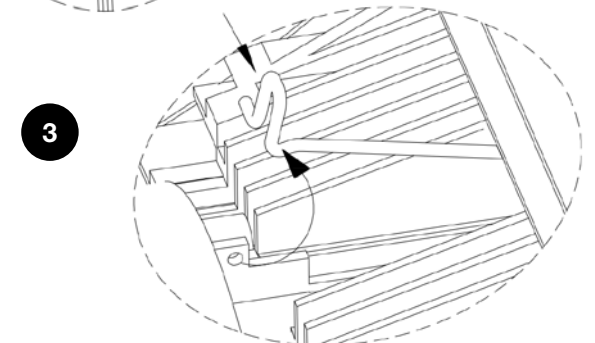
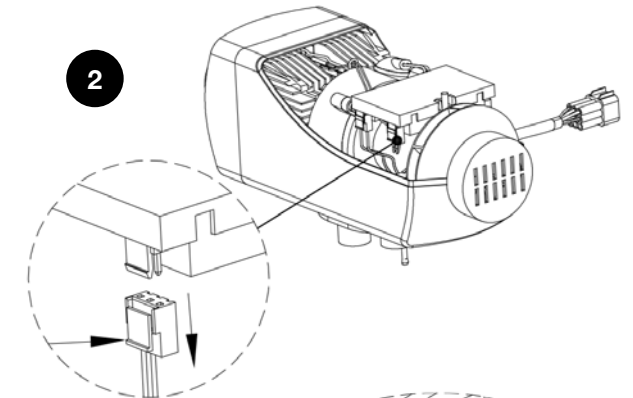
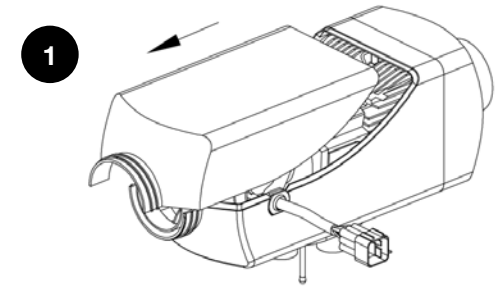

 Please continue on the following page

HOW TO REPLACE THE TEMPERATURE SENSOR - Continued

- Place the new sensor in place and secure with the retaining clip.
 - Route the wire back to the PCB and plug it into the PCB.
 - Replace the upper cover of the heater unit.
- Replace the outer metal cover and test.

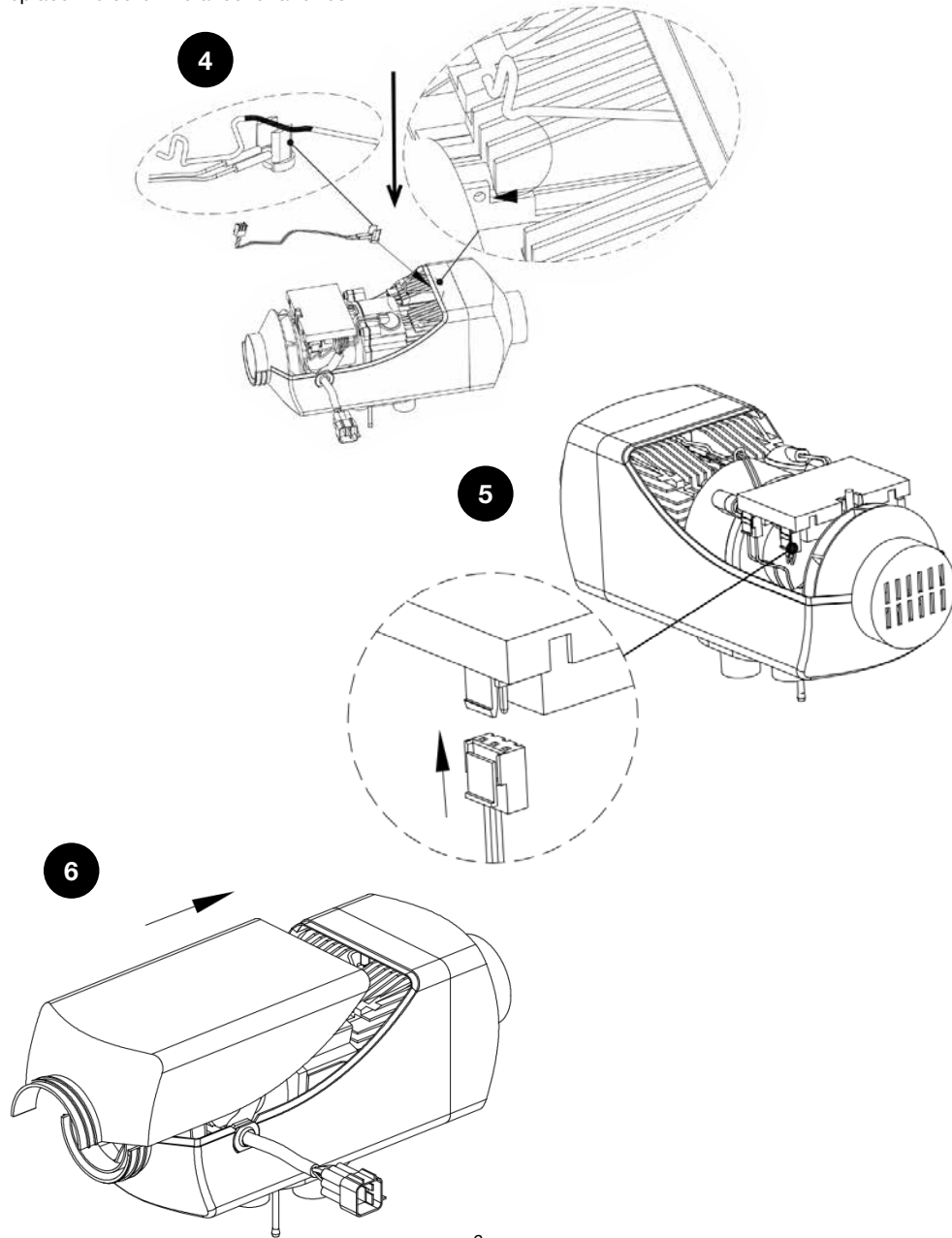

6

HOW TO REPLACE THE PCB

PARTS & TOOLS REQUIRED:

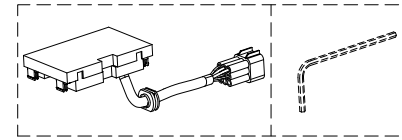

PCB & Harness

Allen Key

After removal of the outer metal cover of the heater, you can access the heater unit. Replacement of the PCB can be done without removing the heater unit from the main case, however you might find it easier to remove it if doing additional work.

- Unplug the main harness connector.
- Remove the upper cover of the heater unit .
- Unscrew the allen bolt securing the PCB assembly in place.
- Carefully lift up the PCB and unplug the connectors for the glow plug, sensors and control before removing it completely.

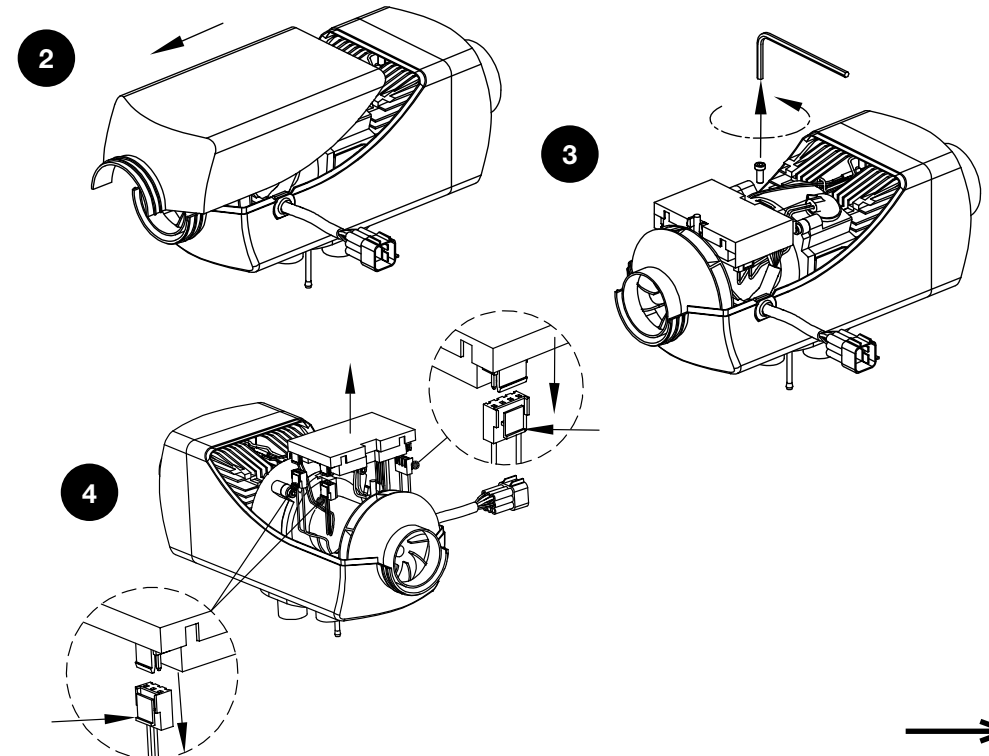

7

➔
Please continue on the following page

HOW TO REPLACE THE PCB - Continued

5. Take the new PCB and insert the connectors for the glow plug and sensors and control. Position it on top of the heater and route the main harness out the side of the case.
6. Attach the bolt to secure the PCB assembly in place.
7. Attach the top cover of the heater.
8. Connect the main harness connector. If the heater unit was removed from the outer case, then re-install. The heater can now be powered up and tested.

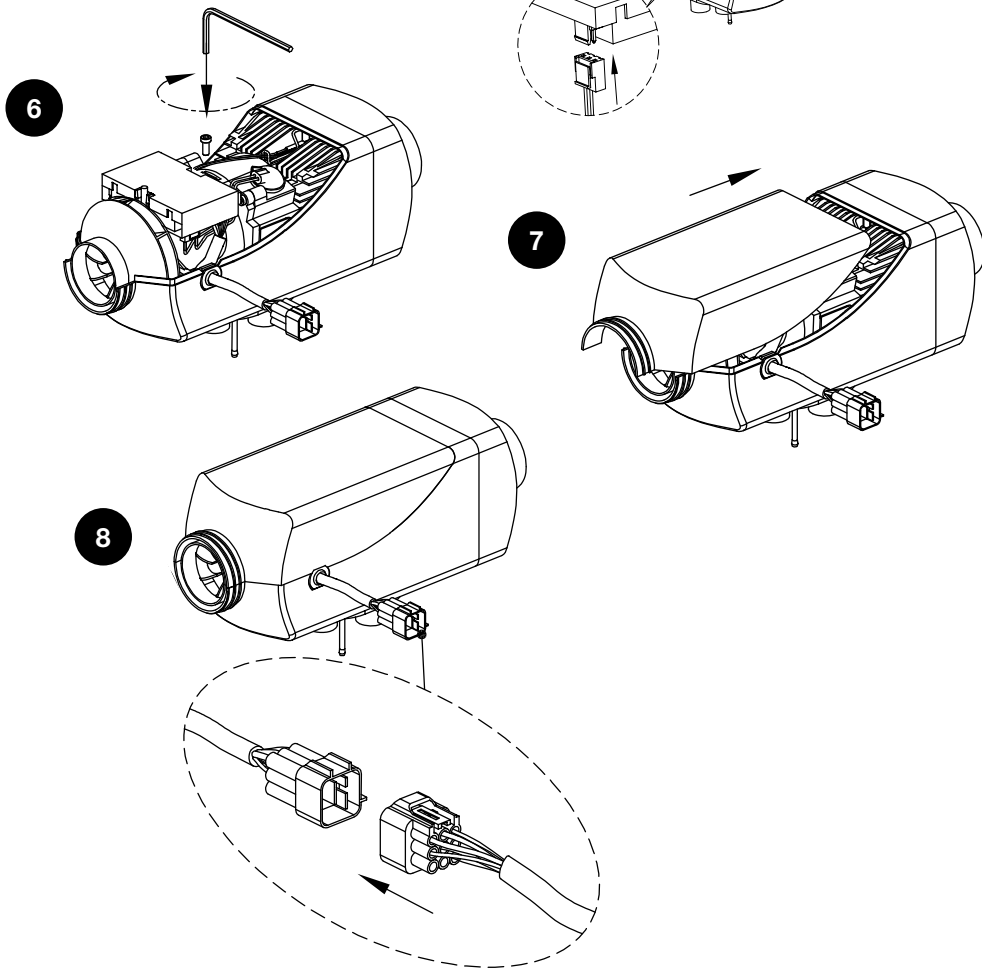

HOW TO REMOVE AND CLEAN THE AIR FILTER

PARTS & TOOLS REQUIRED:

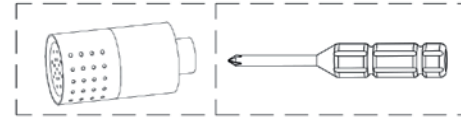

Air Intake Filter **Phillips head screwdriver**

After removal of the outer metal cover of the heater, you can access the heater unit.

1. Unscrew the screw securing the bracket for the intake filter and loosen the hose clamp and remove the intake filter from the intake hose end.
2. Check the intake filter and gently clean it as needed to remove any dust/dirt. If especially dirty it may need to be replaced with a new one. To re-install, insert the filter into the end of the intake hose and tighten the hose clamp securely. Position the intake filter under the bracket and attached the screw to secure it in place.

Reassemble the outer metal case and test.

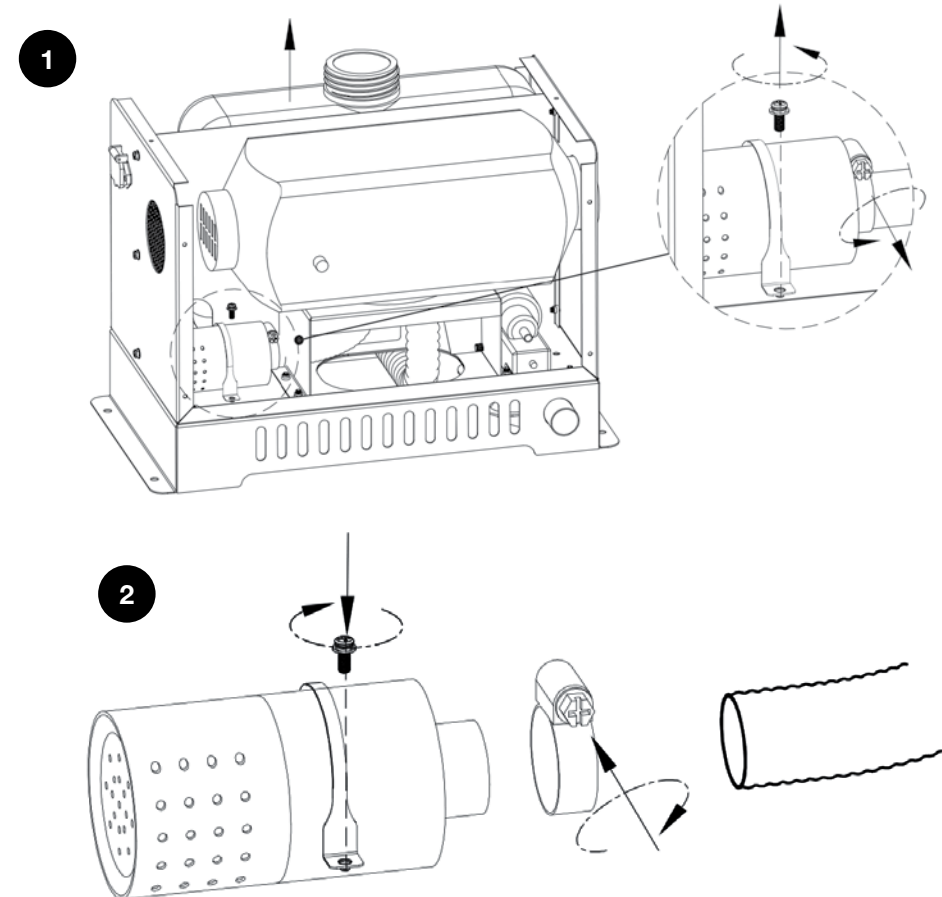

HOW TO CHANGE THE FUEL PUMP

PARTS & TOOLS REQUIRED:

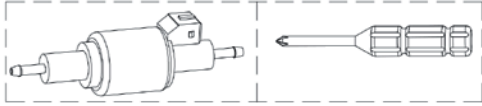

Fuel pump

Phillips head screwdriver

After removal of the outer metal cover of the heater, you can access the heater unit.

Before removing or replacing the fuel pump, it is recommended to first empty the fuel tank and purge the fuel from the fuel lines to prevent spillage during this work.

An alternative is to clamp the fuel line between the tank and pump - however it is critical to ensure the fuel line is not damaged as it could result in fuel leaks, which may not show up immediately.

1. Carefully pull the fuel pump from the main case and access the harness metal clip and lift up to remove. The harness plug can then be removed from the pump. Carefully pull off the fuel line from each end of the pump. Be careful as fuel may leak from the lines after detaching.
2. Once removed, the outer silicone cover on the pump can be removed for re-use on the replacement pump. Installation of the pump is the reverse of the removal. Once the pump is placed back in position and connected up, the fuel tank can be re-filled and the system checked for any leaks. Reassemble the outer metal case and test.

Please note that you may need to prime the fuel system before the heater will start, particularly if you have emptied the fuel tank.

it is recommended to remove the case after testing and reconfirm there are no fuel leaks.

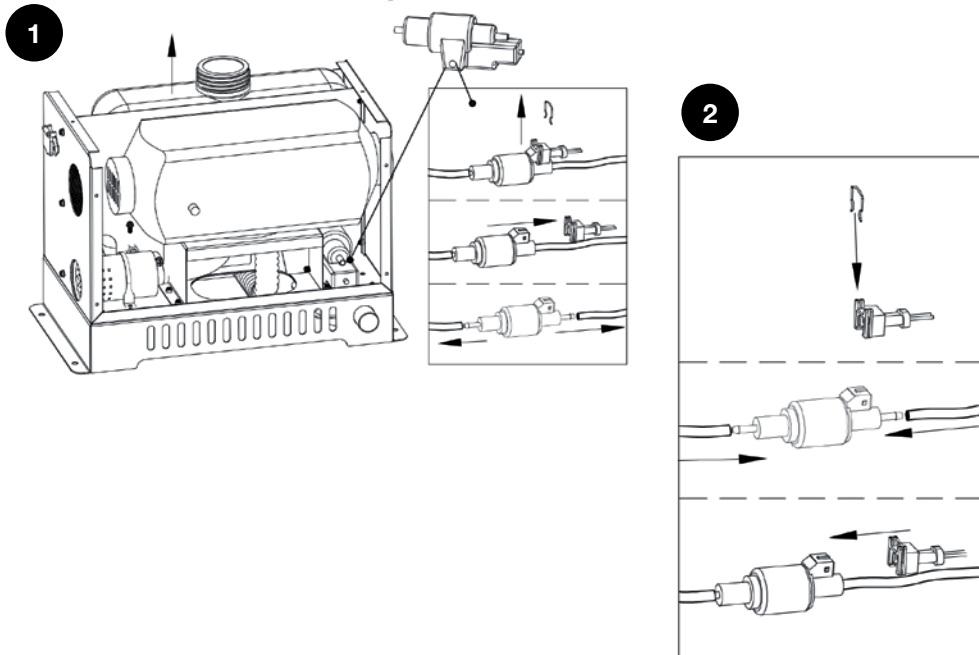

MAIN PARTS OF HEATER UNIT

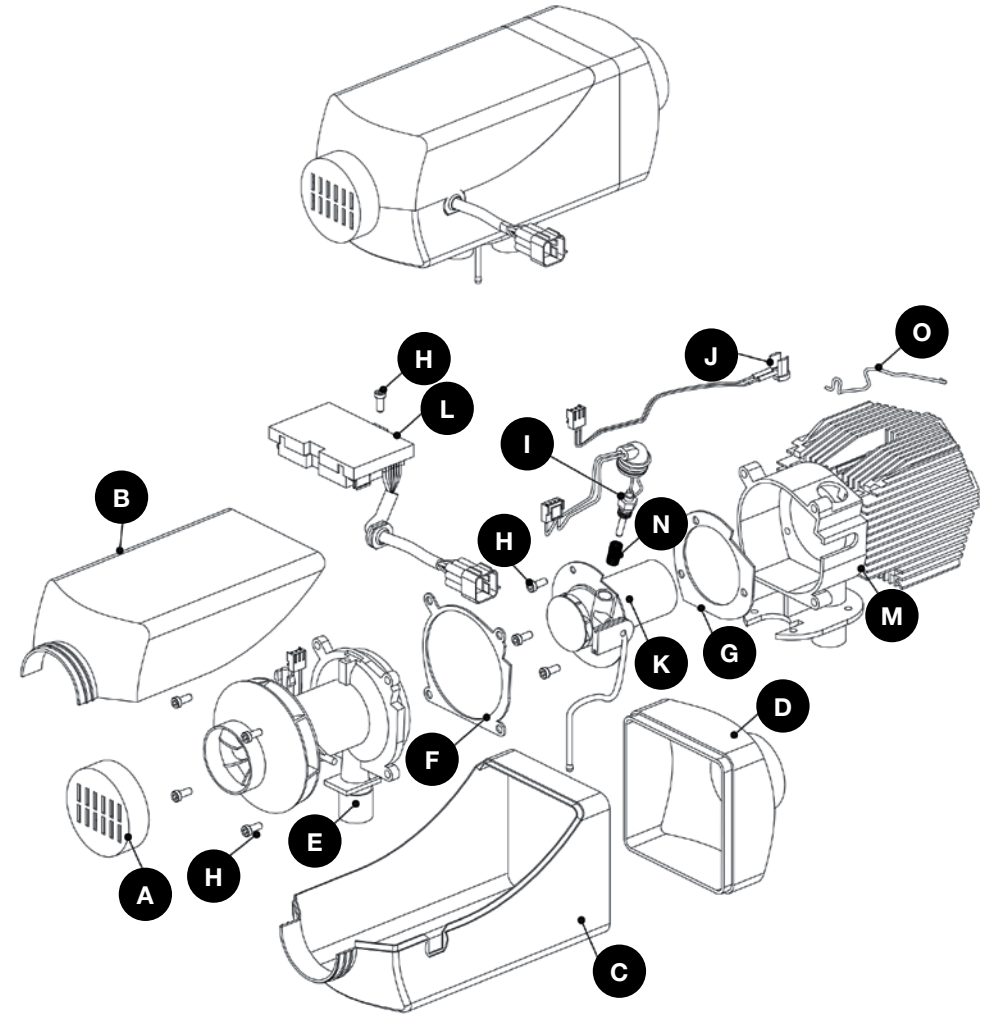

- A. Twist cap (not included in this model)
- B. Top cover
- C. Bottom cover
- D. Air outlet cover
- E. Fan Motor
- F. Gasket A
- G. Gasket B
- H. Screw

- I. Glow plug
- J. Temperature sensor
- K. Combustion chamber
- L. Main PCB
- M. Heat exchanger
- N. Atomizing net
- O. Snap ring

HOW TO DISASSEMBLE THE COMBUSTION CHAMBER

TOOLS REQUIRED:

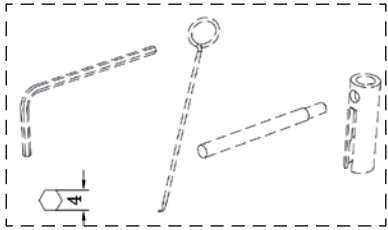

Service Toolkit

After removal of the outer metal cover of the heater, you can access the heater unit. The heater unit will need to be removed from the main case to disassemble the heat exchanger. To do so, it is recommended to first empty the fuel tank and purge the fuel from the fuel lines to prevent spillage. Tip the unit on its side to access the bottom and loosen the clamps securing the exhaust and combustion intake pipes. Also disconnect the fuel line from the bottom of the heater unit. Undo the bolts securing the heater unit to the main case, then you can tilt the body up again. Lift out the heater unit.

1. Unplug the main harness connector.
2. Remove the upper cover of the heater unit .
3. Lift out the body of the heater from the case by tilting the front up and sliding the body towards you.

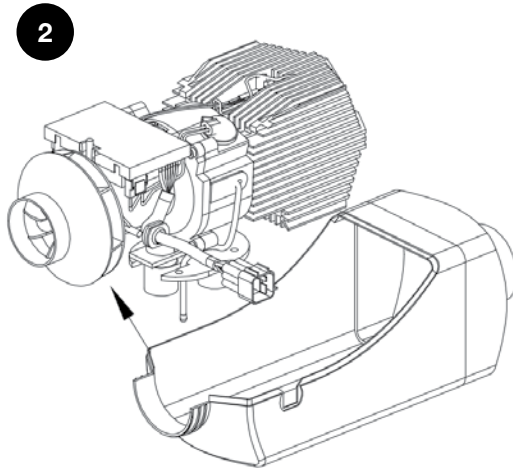
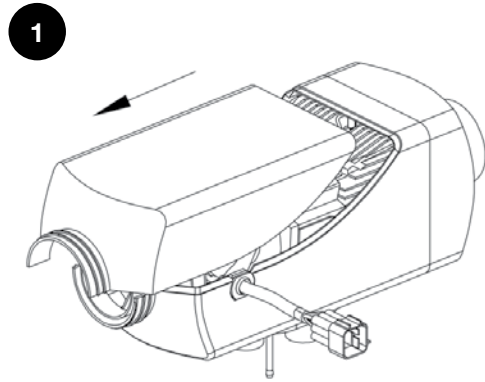
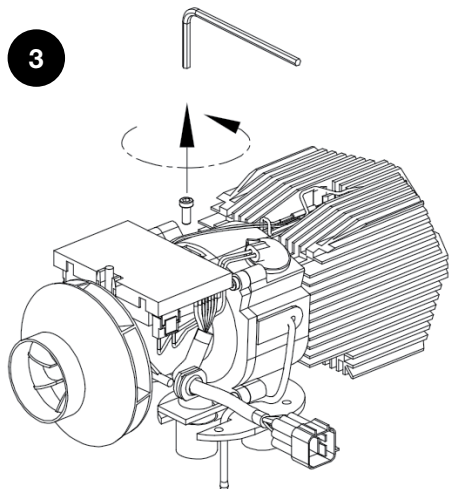

HOW TO DISASSEMBLE THE COMBUSTION CHAMBER - Continued

4. Unscrew the allen bolt securing the PCB assembly in place. Carefully lift up the PCB and unplug the connectors for the glow plug, sensors and control before removing it completely.
5. Remove the Glow plug from the body using the special tool from the Service Toolkit. Be careful not to twist the wire harness as you loosen the Glow plug. Once loosened, carefully lift it out of the body. Remove the bolts securing the fan assembly to the main body and remove.

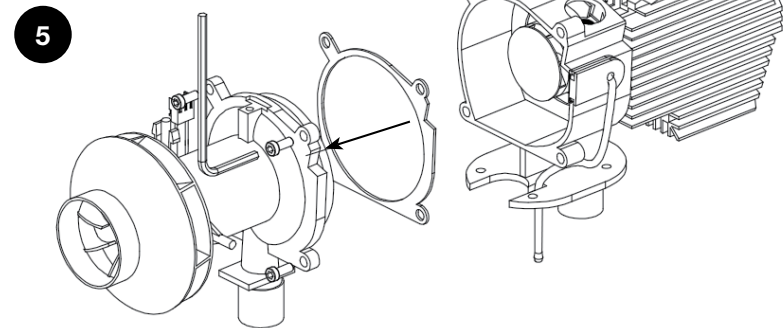
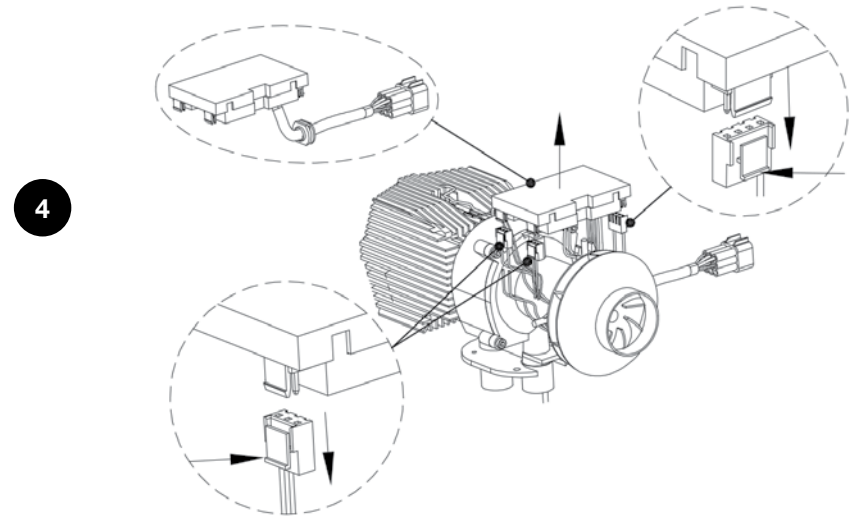

Please continue on the following page



Please continue on the following page

HOW TO DISASSEMBLE THE COMBUSTION CHAMBER - Continued

- Remove the 3 bolts securing the combustion chamber to the heat exchanger then slide it out. Then, using the hook tool from the Service Toolkit carefully remove the atomizing net from the combustion chamber body.
- Inspect the combustion chamber, atomizing net and inside of the heat exchanger/main body for deposits and carbon buildup. To clean you can prepare a solution of mild detergent and warm water. You can soak the parts in the solution to help remove the deposits and brush the surfaces with a soft brush until clean. Check the atomizing net and if still blocked it may need replacing. Once clean, rinse all traces of detergent and allow to air dry completely before re-assembly.

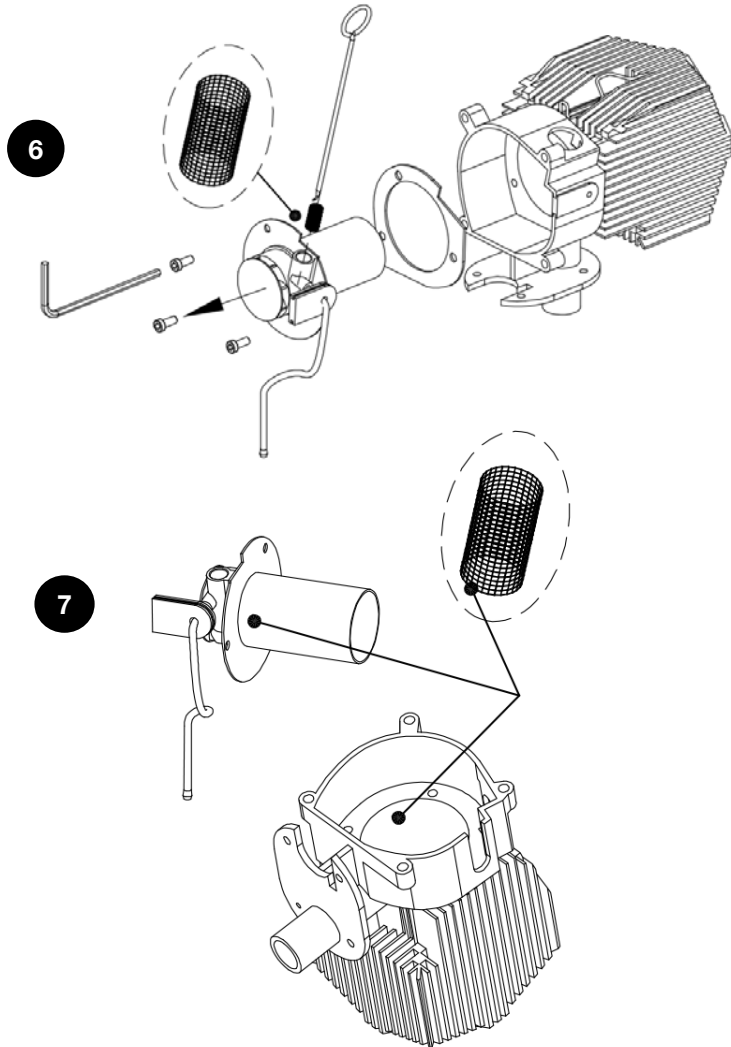

Please continue on the following page

HOW TO DISASSEMBLE THE COMBUSTION CHAMBER - Continued

- Insert the clean (or new) Atomizing net using the special insertion tool from the Service Toolkit. If replacing the inner combustion chamber gasket (Gasket A), ensure the old one is removed and the sealing surfaces are clean and dry. Position it in place and then slide the Combustion chamber in place and install the 3 bolts and tighten.
- If replacing the outer gasket (Gasket B), ensure the old one is removed and the sealing surfaces are clean and dry. Position it in place and then slide the Fan assembly in place and install the bolts and tighten.

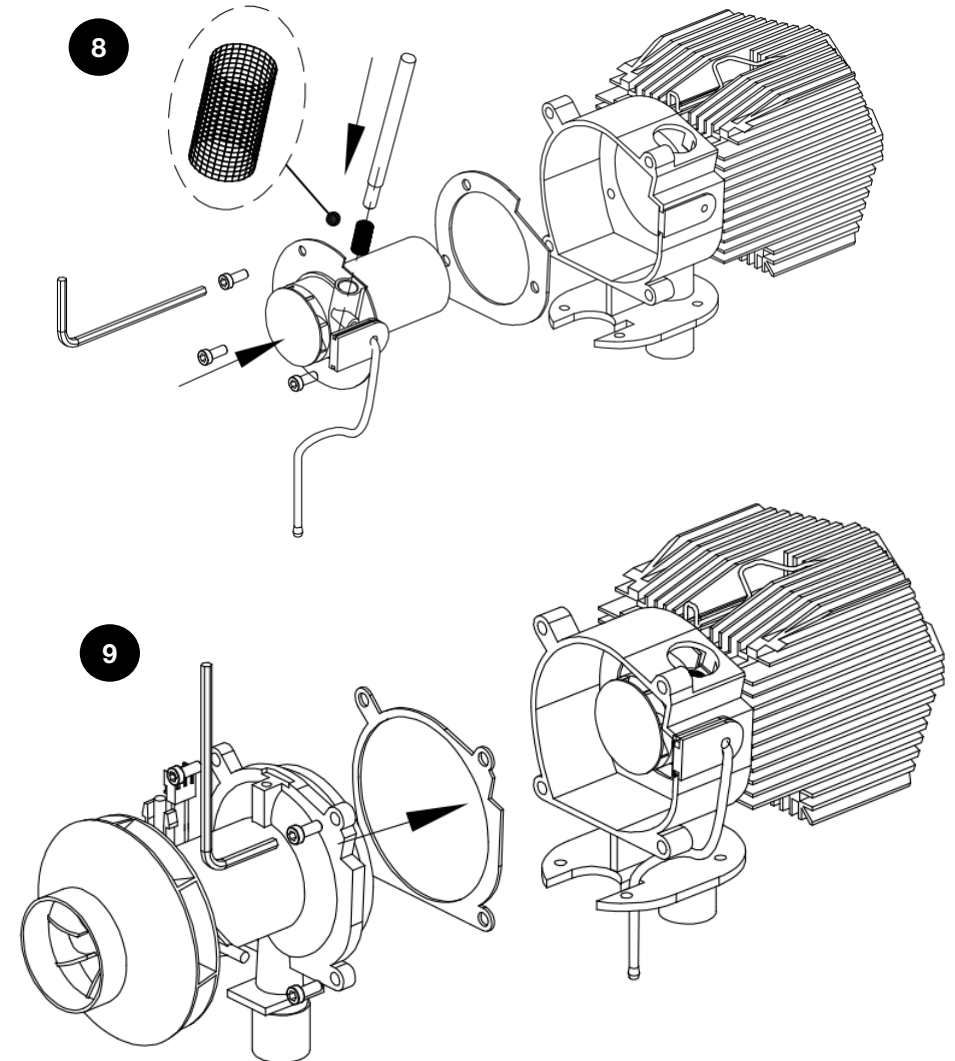

Please continue on the following page

HOW TO DISASSEMBLE THE COMBUSTION CHAMBER - Continued

10. The Glow plug can be installed using the special tool from the Service Toolkit. As with removal, be very careful not to twist the wires coming out of the Glow plug when tightening it in place. Secure the rubber cap and route the wires.
11. Attach the connectors for the glow plug and sensors and control to the PCB. Position the PCB on top of the heater.

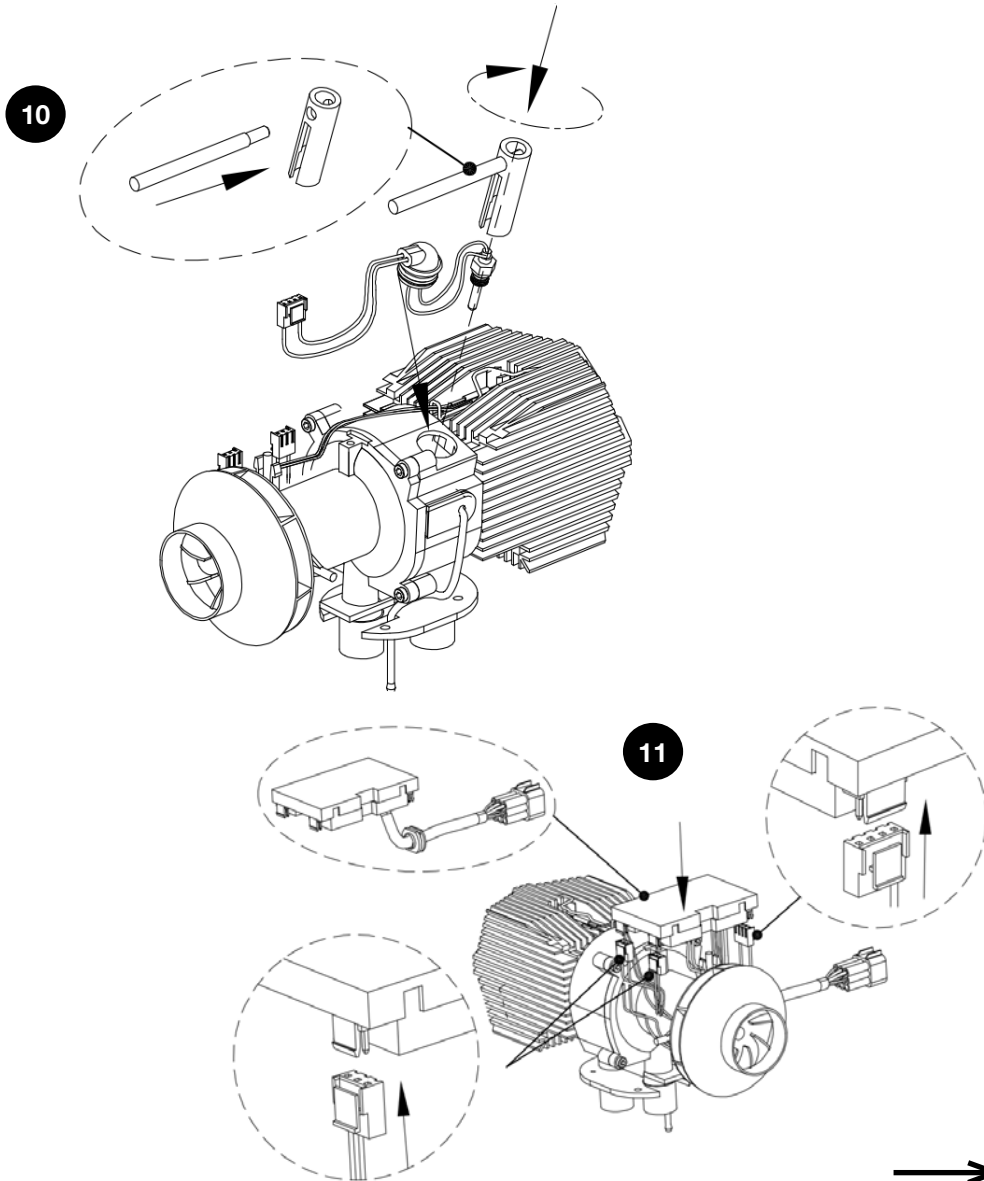

HOW TO DISASSEMBLE THE COMBUSTION CHAMBER - Continued

12. Attach the bolt to secure the PCB assembly in place.
13. Install the main body into the Bottom case.

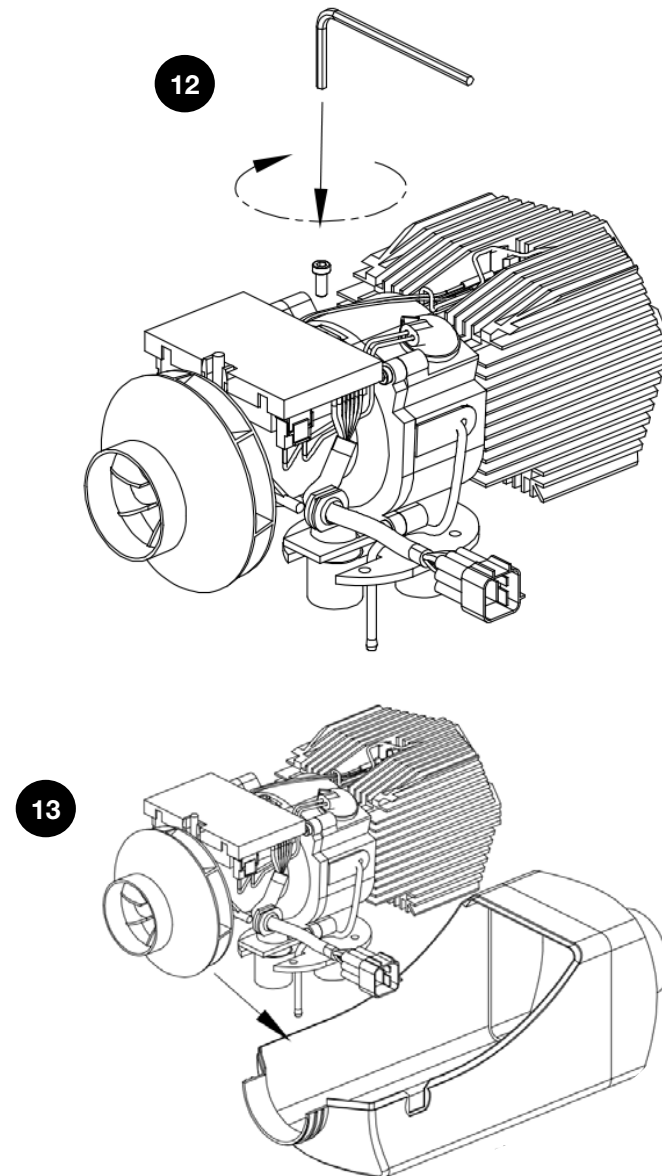

HOW TO DISASSEMBLE THE COMBUSTION CHAMBER - Continued

14. Attach the top cover of the heater.

Connect the main harness connector. Install the heater unit into the outer case, tighten the bolts and attach the exhaust and combustion air intake pipes and tighten the clamps. Attach the fuel line to the bottom of the heater. Fill the fuel tank. Please note that you may need to prime the fuel system before the heater will start, particularly if you have emptied the fuel tank. The heater can now be powered up and tested.

It is recommended to remove the case after testing and reconfirm there are no fuel leaks.

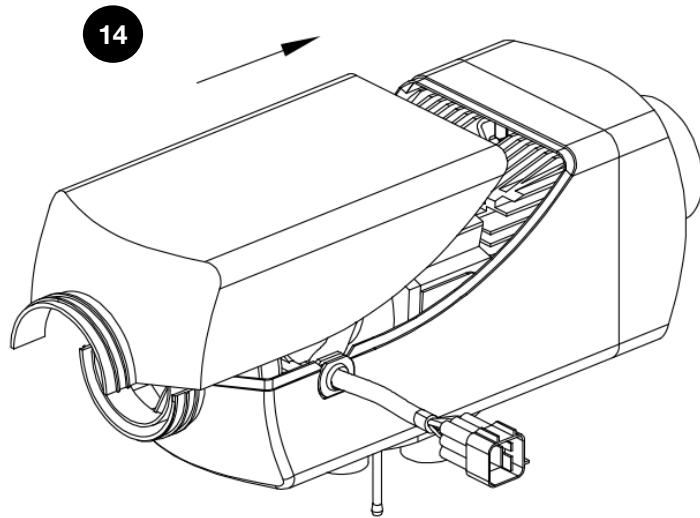

REMOVING DUST AND DEBRIS FROM THE EXTERIOR SURFACES

It is important to start by removing any loose dust and debris from the exterior surfaces of your diesel heater.

1. Gently brush off any visible dust using a soft-bristled brush or a microfiber cloth. Make sure to target all areas, including the vents, knobs, and corners.
2. If the dust/dirt is stubborn and difficult to remove, you can use a low-pressure air blower or a can of compressed air to blow away the particles without causing any damage.

DRAINING AND CLEANING THE FUEL TANK

To begin cleaning the fuel system of your diesel heater, you must first drain and clean the fuel tank. This ensures that any accumulated dirt, water, or sediment is removed, preventing it from clogging the fuel lines and filters.

1. Turn off the heater and disconnect the power source
2. Remove the outer metal cover to access the fuel tank. If the tank is quite full you can choose to carefully pour the fuel into a suitable container via the filler spout at the top. Otherwise it can be easier to remove the fuel line from the lower part of the tank.
3. Place a suitable container beneath the fuel line connection point on the tank to collect the fuel.
4. Carefully pull off the fuel line to drain the fuel from the tank, ensuring that you don't spill any.
5. Once the tank is empty, carefully remove any remaining fuel with a hand pump or syphon.
6. After draining the fuel, inspect the tank for any signs of damage. If necessary, clean the tank with a mild detergent and a soft brush, removing any residue that may have accumulated.
7. Rinse the tank thoroughly with clean water and allow it to dry completely before refilling it with fresh diesel fuel.

FLUSHING THE FUEL LINES

Flushing the fuel lines of your diesel heater is the final step in cleaning the fuel system, ensuring that any remaining impurities are removed and the system is free of debris.

1. Identify the fuel line connections, located near the fuel tank, fuel pump and heater unit.
2. Disconnect the fuel lines, taking note of their respective positions.
3. Using a suitable container or fuel line flushing kit, flush each line separately by applying compressed air or diesel fuel in the opposite direction of fuel flow.
4. Observe the expelled fuel for any signs of contamination or debris.
5. If necessary, repeat the flushing process until the expelled fuel appears clean and free of impurities.
6. Once the lines are flushed, reconnect them securely, ensuring proper alignment and tight fittings.

Once the fuel lines and tank have been reassembled and checked, the fuel tank can be refilled with fresh diesel fuel.

NOTE: it is highly recommended not to re-use the fuel removed from the tank as it may re-introduce impurities into the system.

Once refuelled you can test the heater.

Please note that you will need to prime the fuel system before the heater will start (refer to the user manual for details).

It is recommended to remove the case after testing and reconfirm there are no fuel leaks.

Important: Retain these instructions for future use.

For any queries or assistance call



Customer Service (Australia Only)

1300 174 876

Hours of operation:
Monday to Friday 8am - 5pm EST

Do not return to place of purchase.

Keep your purchase receipt, this will be required to make any claims under the 1 year warranty.

Gasmate[®]